

This meet is an Invitational. If your team is interested in competing please contact Mellanee Welty at mellaneew@gators.ufl.edu



REVISED

**UNIVERSITY OF FLORIDA
TOM JONES MEMORIAL
GAINESVILLE, FL
FRIDAY, APRIL 22nd, 2016**

SCHEDULE OF EVENTS

FIELD EVENTS:

11:00am	M Hammer
	W Discus
	W Pole Vault
	W Long Jump
12:30pm	W Hammer
	M Discus
1:00pm	M High Jump
2:00pm	M Long Jump
	W Triple Jump
2:30pm	W Shot Put
3:30pm	W Javelin
	W High Jump
4:00pm	M Pole Vault
4:30pm	M Shot Put
	M Triple Jump
5:00pm	M Javelin

RUNNING EVENTS:

1:00pm	W 100m Hurdles (P)
	W 100m Hurdles Intl (P)
1:15pm	M 110m Hurdles (P)
	M 110m Hurdles Intl (P)
	BREAK
2:00pm	W 4x100
2:05pm	M 4x100
2:15pm	W Steeple
2:30pm	M Steeple
2:50pm	W 100m Hurdles (F)
	W 100m Hurdles Intl (F)
3:00pm	M 110m Hurdles (F)
	M 110m Hurdles Intl (F)
3:10pm	W 100m
3:25pm	M 100m
3:45pm	W 400m
4:00pm	M 400m
4:15pm	W 800m
4:30pm	M 800m
4:45pm	W 400m Hurdles
4:55pm	M 400m Hurdles
5:10pm	W 3K
5:25pm	M 3K
5:40pm	W 200m
6:00pm	M 200m
6:20pm	W 1500m
6:35pm	M 1500m
6:55pm	W 4x400
7:05pm	M 4x400

FACILITY:

- Track: Mondo surface – 9-48” lanes
- Field Events: Double field event areas in the long and triple jump, high jump, shot put, discus and pole vault.
- Spikes: 1/4” pyramids

CONDUCT OF MEET:

- The meet will be conducted per the 2016 NCAA Rules Manual.
- Running events will be seeded and conducted as finals, in sections against time if more than one section required.
- In the long jump, triple jump, shot put, discus, hammer and javelin all participants will be allowed 3 trials with the top 9 marks advancing to the finals.

RULES/ELIGIBILITY:

- Events will be conducted under NCAA rules. All athletes representing intercollegiate programs must be eligible according to respective NCAA rules.

ENTRY INFORMATION:

- 1) \$30.00 per athlete entered (max \$350 per team/\$700 both). \$5.00 for unattached athletes that show a valid college id. Entry fees must be paid at packet pick-up. Make checks payable to “University Athletic Association”.
Only accept cash and check.
- 2) All entries must be submitted through Direct Athletics.
- 3) Entries are due by Wednesday, April 13th, 2016 at 12:00pm (noon).
- 4) We will not accept all unattached entries. Accepted Unattached entries will be posted on Gatorzone.com Friday, April 15th.

ATHLETE CHECK-IN:

- Athlete check-in and staging area will be at the north end of the track.
- Athletes must check in one hour before scheduled event time.

TENT POLICY

The UAA requires all on-site tents be anchored by weights. The UAA reserves the right to have unsecure tents removed if they are considered unsafe. Unsafe conditions would include, but are not limited to, weather/wind conditions and the overall condition (wear and tear) of the tent.

WEIGH-IN SCHEDULE

9:00am-12:00pm

PACKET PICKUP

Packet Pick-up will be held at the Women’s Club (across the street from the track).
Packet Pick-up will begin at 9:00am and go through 4pm.

FOR MORE INFORMATION CONTACT:

Mellanee Welty : MellaneeW@gators.ufl.edu

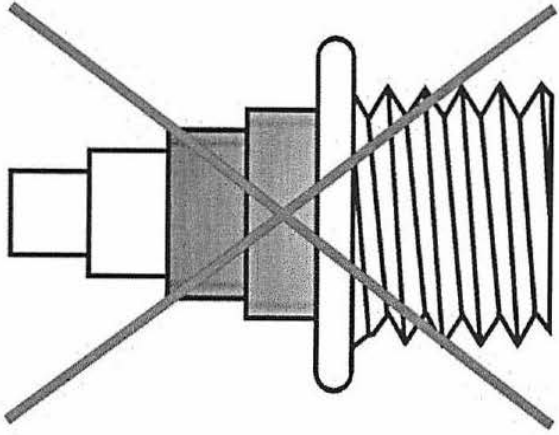

NO

**Christmas
Tree Spike
Pins**

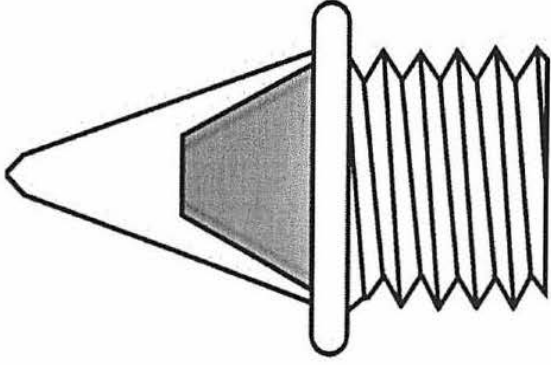

1/4"

Pyramid

Item #463A from
MF Athletics
800-693-6052

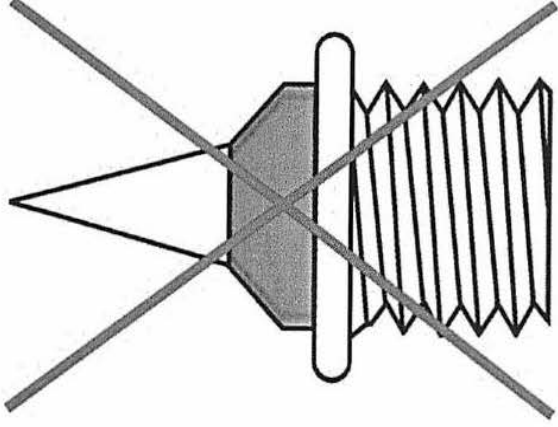

NO

**Needle
Spike
Pins**